

National Child Safety Council

Bicycle Safety

Manual

Check
out my new bike!
Let's learn to ride
safely!



© MMIX National Child Safety Council,
Jackson, MI 49204-1368 • The name and
character "Safetyup" and "Spike" the
Bike™ are the property of NCSA.
All Rights Reserved • LTHO USA

A Few Words from . . .

THE DESCHUTES COUNTY SHERIFF'S OFFICE
LARRY BLANTON, SHERIFF

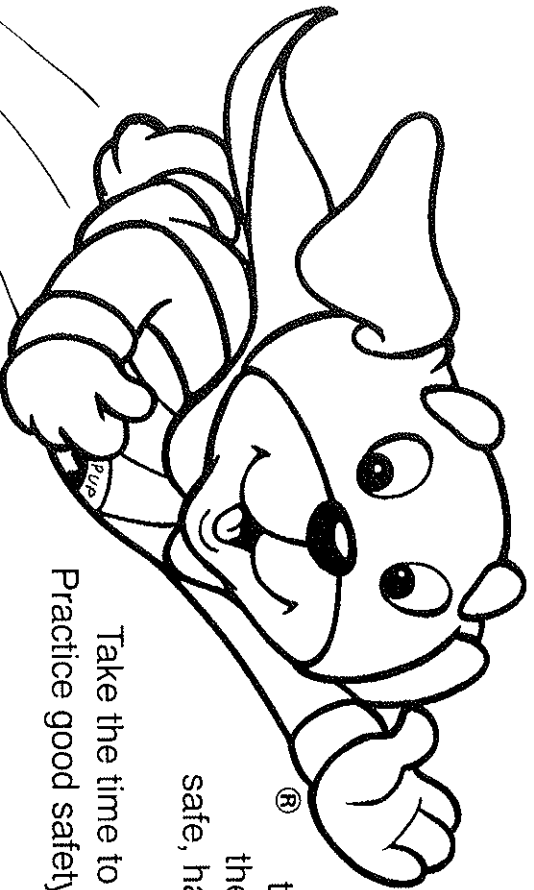

To Parents and Teachers:

Children are our future. We, as parents and teachers, need to teach our children the guidelines for living safely every day. Emphasizing the importance of responsibility and respect for themselves and others will enable children to become safe, happy, and productive citizens.

Take the time to go over the material in this manual with your children. Practice good safety habits; a good example speaks louder than words.

To The Young People:

If safety isn't first, second won't count.™

Learn the ways of safe living and how to help prevent accidents from happening. Complete each game and puzzle. Then, show others how easy it is to live safely by applying each rule to everyday life.

Please complete the thank you note on pages 1 and 2 and send it to one of the people in your community who helped make this manual possible.

Stay safe and sound, and I'll see you around!®

Introduction

Hey boys and girls!

Hey Safetypup®, "What can I do for you?"

You are invited to sign up for our bike safety rally and parade and the whole community is going to be there. *Be ready for the ride of your lives!*

Learn to be safe bike riders. Use this manual to get your bikes in shape and brush up on your safety skills.

Hi Budi!
I'm looking for a new bike to take to the bike rally!

Great! I've got just the thing!

Parents and Law Enforcement Officers

Show children the importance of bicycle safety rules and how they can help prevent accidents and save lives. Prepare them for the rally by reviewing each page with them and encouraging them to practice safe riding habits.

Remind children to complete and mail the thank you note on this page to the people in your community who helped make this manual possible.

Thank You!

National Child Safety Council, Safetypup®, and the writer of this note would like to thank you for your active interest in the safety education of the children in your community.

Great!
Let's go inside and see what you have!

End

LESSON Guide

Use this lesson guide with your own activities to reinforce the safety rules and to make sure the objectives of this manual are reached.

Pages 4/5 - Does Your Bike Fit You? Each child should learn how to determine if their bicycle is appropriate for their size and age. Help them to understand that it is important that the bike fit their body to help prevent accidents from happening. Demonstrate how a bike should fit and how to adjust it if it does not. Remind children that bikes should only have one rider at a time.

Page 6 - Get To Know Your Bike: Point out the 21 parts to a bike and explain why each part is important for every bike to have. Demonstrate how each part works.

Page 7 - Safety Check Your Bike: Airplane pilots must review a checklist before flying. Children should understand that if they safety check their bikes, it may help prevent accidents. Encourage them to review this checklist every time they ride.

Page 8 - Bike Reflectors: Explain to children how reflectors help other drivers to see them especially if they must ride at night. Point out each reflector and where it should be located on the bike. Demonstrate how to adjust reflectors so they are secure. Encourage children to wear white or light-colored clothing if they have to ride at night.

Page 9 - Bike Helmets: Help children realize that wearing a helmet can prevent serious injuries. Review the points to a proper fitting helmet. Encourage children to only use helmets that have been approved by Snell, ANSI, or ASTM. Provide a helmet for the children to try on and learn how to achieve a proper fit.

Page 10 - A Storm Is Coming: Remind children to listen to weather reports and to keep a watchful eye on the weather conditions before riding. Encourage children to NEVER ride their bikes in a storm or when there is bad weather because it can be dangerous. Discuss storms that can occur in your area and what they should do if a storm were to suddenly appear. Discuss what debris may be left as a result of a storm and how it could be a riding hazard.

Page 11 - Hand Signals: Explain the importance of using hand signals if riding where there is traffic. Drivers must signal when they are turning or stopping and it is important for bike riders to do the same for their safety and the safety of others. Review proper hand signals.

School: _____

Name: _____

Age: _____

Dear: _____

Date: _____

Page 12 - Safety Signs: Children should be able to recognize safety signs as well as their shapes, colors, and meanings. Remind children that everyone, including bike riders, need to obey these signs. Give examples of where some of these signs are located.

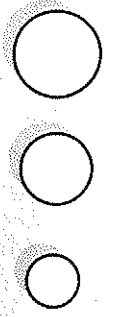

Page 13 - Traffic Safety: Safety signs and traffic lights are for everyone's safety. Review with children what each color represents and how they are to proceed for each sign. Review basic traffic safety rules.

Pages 14/15 - Be Careful When Riding Your Bike: Teach children that riding a bike is a big responsibility and that they need to concentrate on their riding skills to help stay in control. Point out hazards that children may encounter while riding bikes. Explain how these hazards could cause accidents. Give suggestions on how children can avoid these hazards and what can be done to fix them. Remind children to ride at slower speeds when riding on gravel or sand and to always brake before turning to avoid skidding or falling. Have students give other examples of hazards that could cause bike accidents.

Pages 16/17 - A Ride of Rhyme (In The Park): Children should understand that bike safety rules are for their safety and to keep their bikes in good working order. Encourage them to take the responsibility of riding a bike seriously and that they need to do their part to ride safely.

Pages 18/19 - Keep Your Bike Safe and Sound: A bike lock is a very important piece of safety equipment. (A stolen bike can be costly.) Explain to children that they should lock up their bikes no matter where they are and no matter how long they will be leaving their bike unattended. Encourage them to report any stolen bikes to local law enforcement right away. Bring in examples of bike locks and demonstrate how they work.

Pages 20/21 - Rally-Ho! Ready, Set, Go! Bicycle Safety Game: Use this game as a demonstration of the proper way to ride a bike and some of the situations they may encounter. Use it as a review of the basic bike safety rules.

Pages 22/23 - Bike Safety Rally: Give children hands-on experience by organizing a bike rally that will help them practice their safe riding skills. Explain how these activities will increase their skills and make them better bike riders.

Page 24 - Rider Review: Children should review the bike safety rules they have learned. Encourage children to practice bike safety at all times.



Does Your Bike Fit You?

Directions: Read the rules below to be sure your bike fits you.

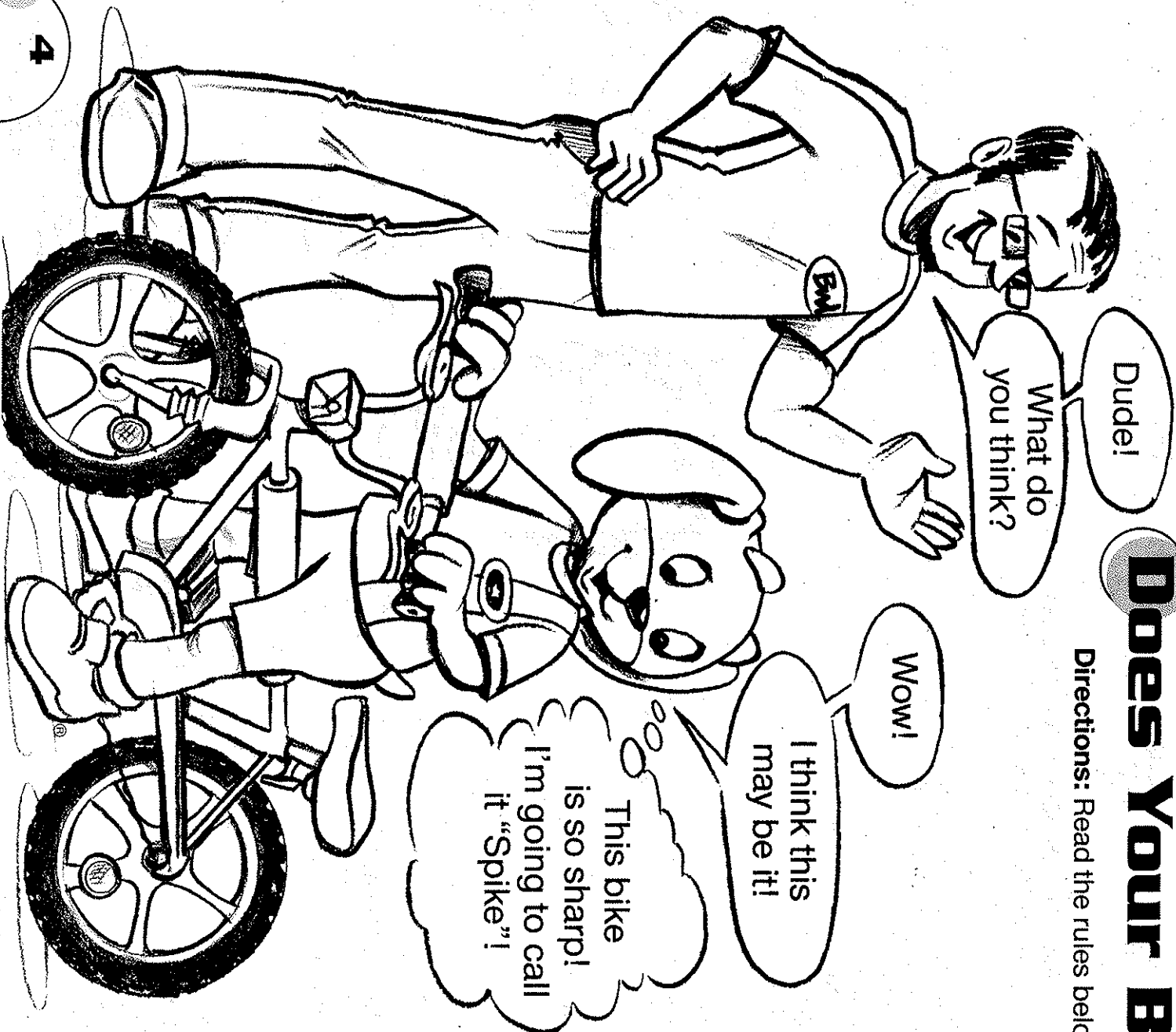

1. When you sit on the seat, do your feet touch the ground? **They should.**

2. When sitting on the seat does your whole foot touch the pedal? **It should.**

3. Do your hands reach the handlebars easily? **They should.**

4. If your bike has a crossbar can you stand over it with both feet flat on the ground and have one inch of clearance? **You should.**

Which Rider...

I know bike safety and just what to do. I always wear a helmet and if baby rides he does, too!

1

Learning to ride is fun to do. I use 4 wheels, instead of 2!

2

I like to ride my bike. It's cool. I follow every safety rule!

3

"Do you?"



For Which Bike?

Directions: Write the number of each rider beside the bike that fits them. Read the clues as you go.

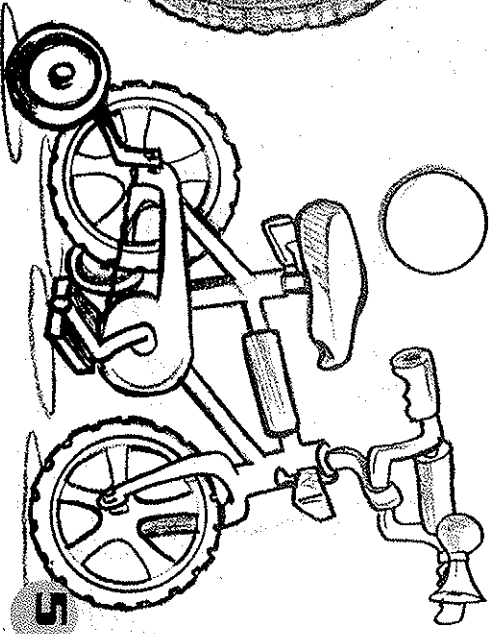
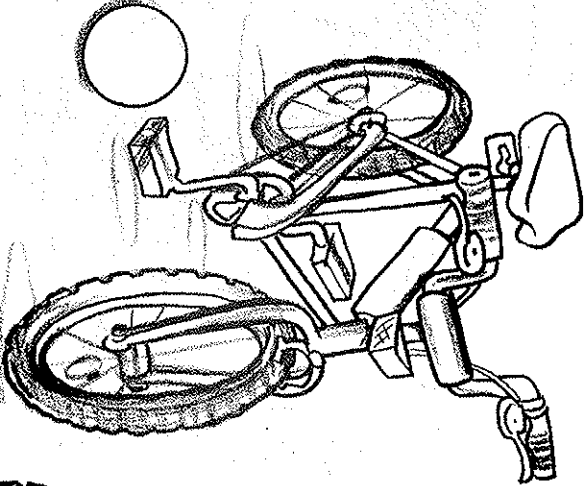
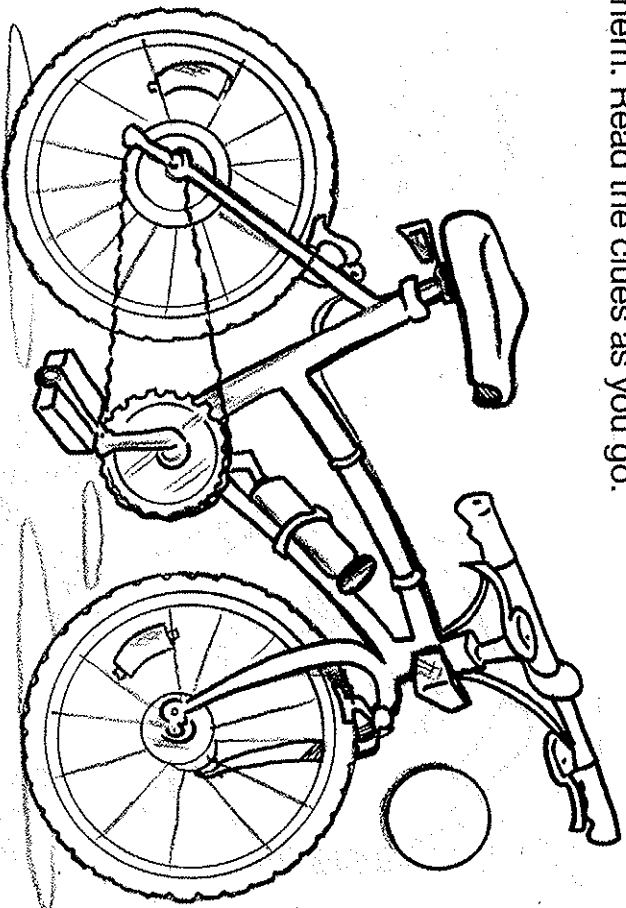

5

To carry things while riding, use the basket or carrier on your bike or a backpack to keep your hands free for steering.

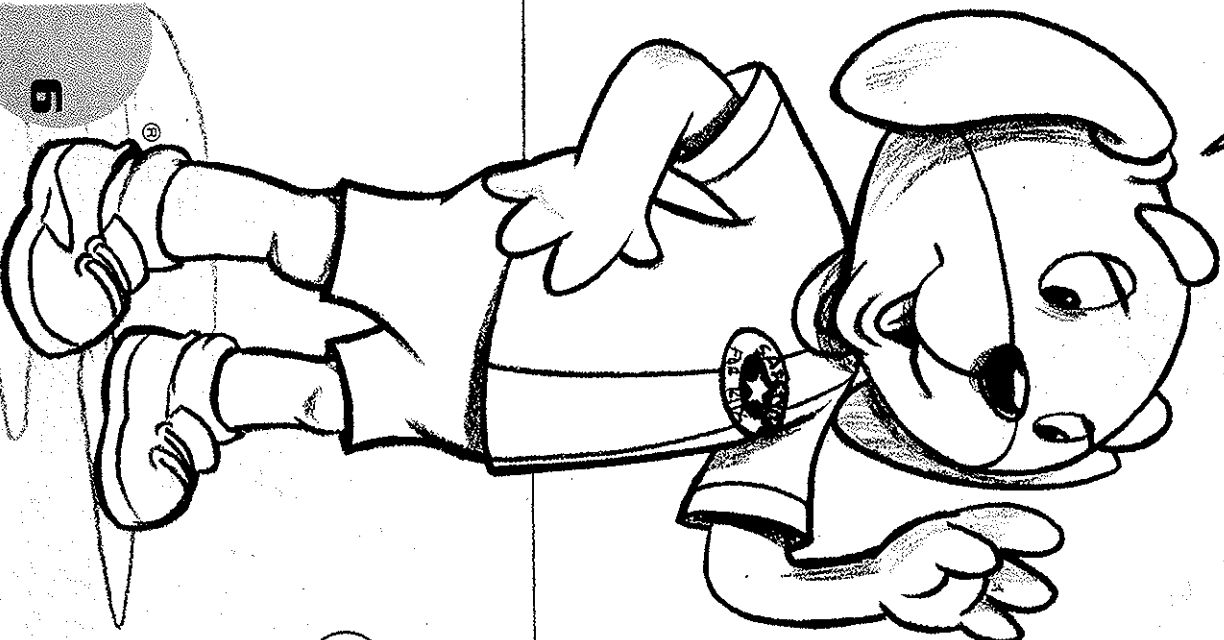

Get To Know Your Bike!

Directions: Read the list of bike parts. Find each part on the bike and write that number in the circle.

Bicycle parts:

- | | | | |
|--------------------|-----------------|---------------------|----------------------|
| 1. seat (saddle) | 8. pedal | 14. rear reflector | 18. wheel |
| 2. handlebars | 9. chain | 15. horn | 19. spokes |
| 3. handlebar grips | 10. chain guard | 16. light | 20. wheel reflectors |
| 4. frame | 11. padding | 17. pedal reflector | 21. valve |
| 5. front brake | 12. kick stand | 13. front reflector | |
| 6. brake cable | | | |
| 7. rear brake | | | |

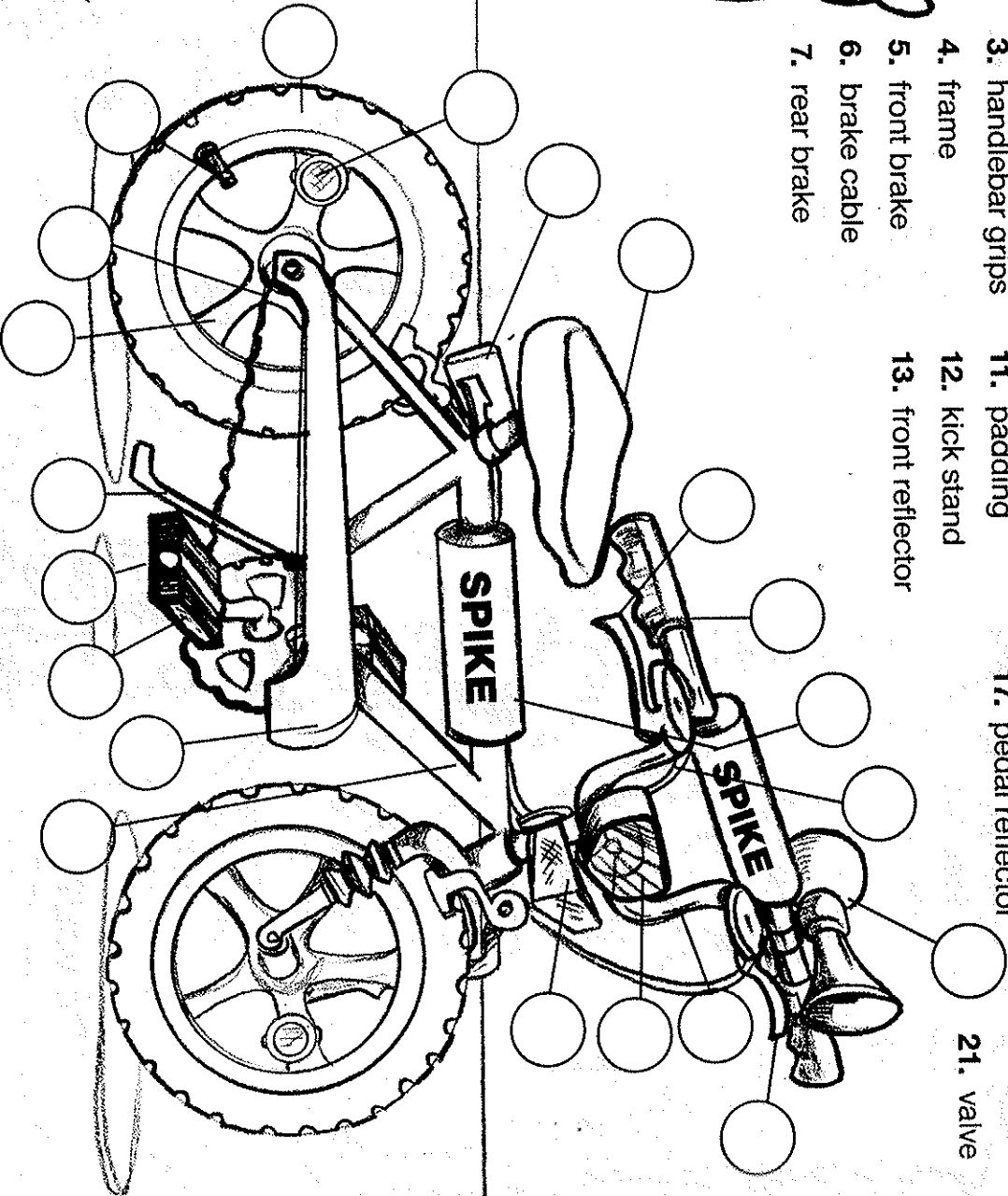



Check!

Safety Check Your Bike:



Directions: Read the list. Put a check mark in the boxes next to the things that are okay on YOUR bike.

- I have reflectors on the front and back of my bike and on my pedals and wheels.
- My brakes work smoothly and at the first touch.
- My tires have enough air and have no cracks, cuts, or bulges.
- My handlebars and seat are tight and not wobbly.
- My chain fits tightly, is oiled, and does not have any damaged links.
- I keep my bike well-oiled and clean.
- I have a light that works in case I have to ride at night.
- The wheels of my bike are not loose and have no broken spokes.
- I take my bike to a bike mechanic or bike shop at least once a year for a check up.
- I make sure my pant legs are secure to my legs when I ride.

Have an adult help you fix things that do not "check out."

Directions: Trace the grey letters to spell out where each reflector is on a bike. Then color the reflectors.

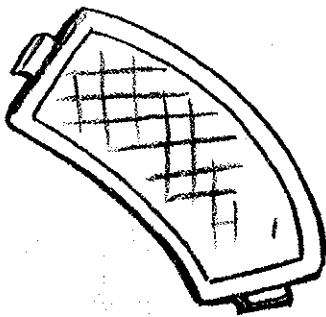

WHEELS

(orange)

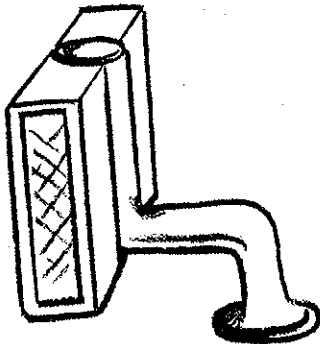

(orange)

PEEPL

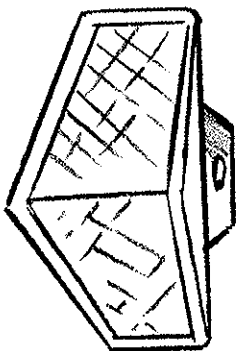

(white)

FRONT

REAR

(red)

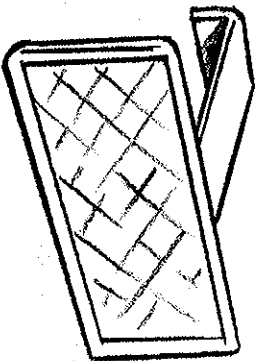

Bike Reflectors...

...are very important.

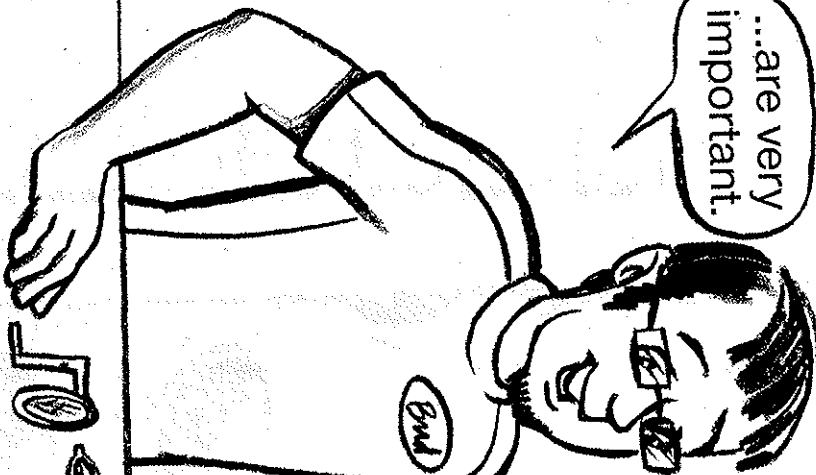

Which one do I need?

Well...
...all of them!

Reflectors shine when light hits them to help others see where you and your bike are.
Wear reflective, white, bright- or light-colored clothes any time you ride, both day and night.

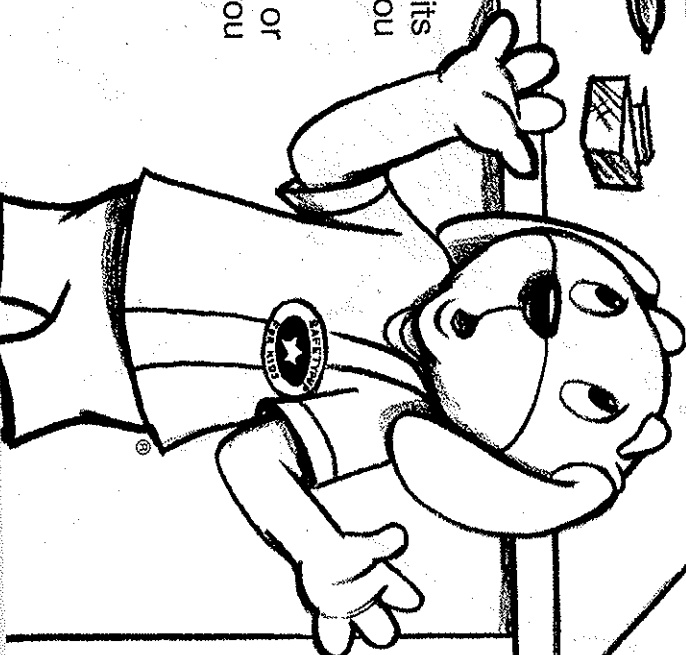

Bike Helmets

Directions: Use the Word Bank to complete the rules and crossword puzzle.

Never wear earphones when riding. It will keep your helmet from fitting right and keep you from hearing what is going on around you.

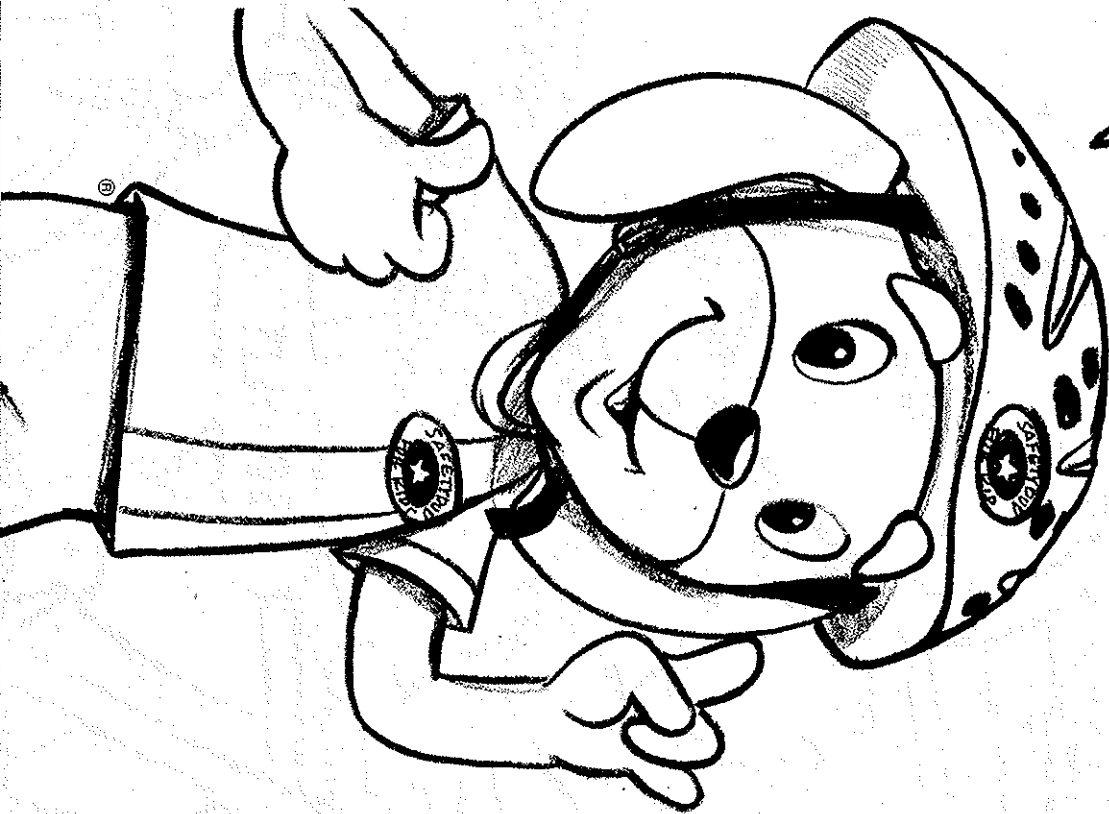

1. Be sure the helmet does not slip forward, backward, up, or _____.
1 Down
2. The _____ strap should be strong and snug, but not hurt.
2 Across
3. Helmet holes and padding should let you _____ and see okay.
3 Down
4. Buy a new helmet if yours is too _____, damaged, or over 5 years old.
4 Across
5. Wear the helmet _____ on the forehead, level from front to back, just above the eyebrows.
5 Down
6. Always wear a _____ - approved helmet.
4 Down
7. Buy a helmet that _____ now, not one to grow into.
6 Across

Word Bank:

- hear
- fits
- small
- low
- down
- chin
- safety

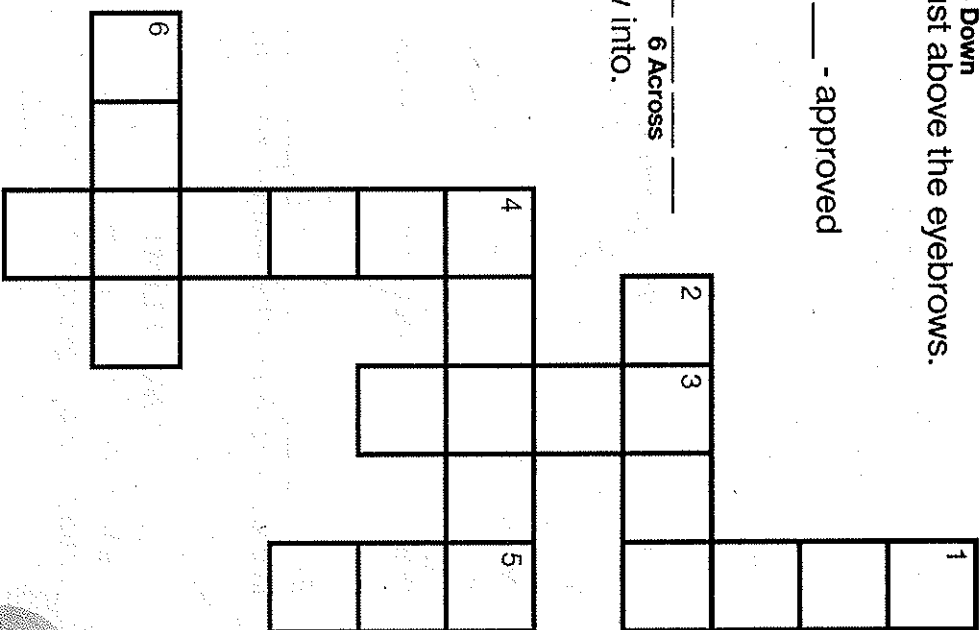

A Storm Is Coming!

Directions: Use the words from the Word List below to complete the rap of storm safety rules.

1. Never ride during a _____. Stay inside safe and warm.
2. Go to the _____ when the storm is bad, near an adult like mom or dad.
3. Listen to the _____ for weather info. You will hear the "all clear" when it is safe to go.
4. Always ask an adult before going _____ . They will tell you when it is safe to ride.
5. When riding your bike _____ a storm, beware of _____ that will warn, "Do not touch." Tell a grown up right away!
6. Be a _____ in every way. Watch the weather every day.

Word List:

safe rider outside powerlines
radio after basement storm

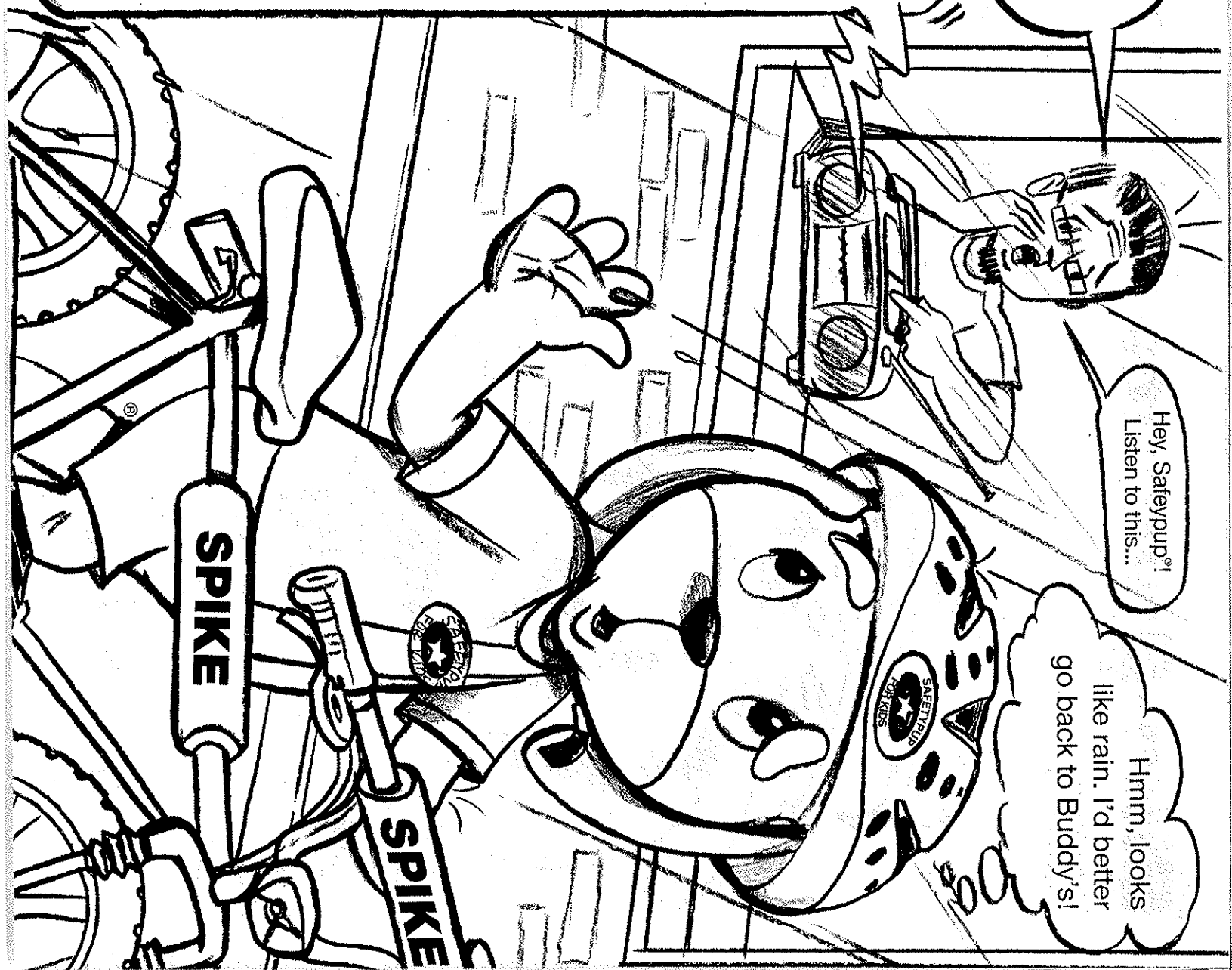

Hand Signals

Directions: Help SafetyPup® find his way to the park. Draw a line in the maze from Start to Finish. Use the hand signal code to find the right symbol for each turn you make in the maze. Draw them in the circles of the maze. The first one is done for you.

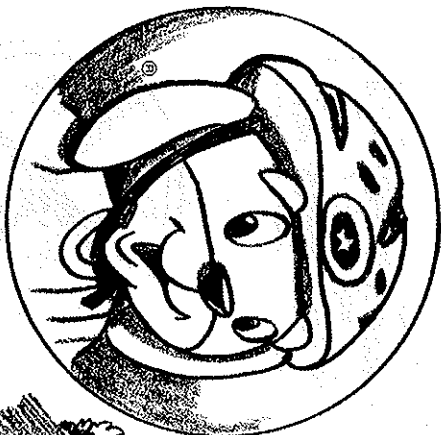

Use hand signals when turning or stopping to let others know what you plan to do.

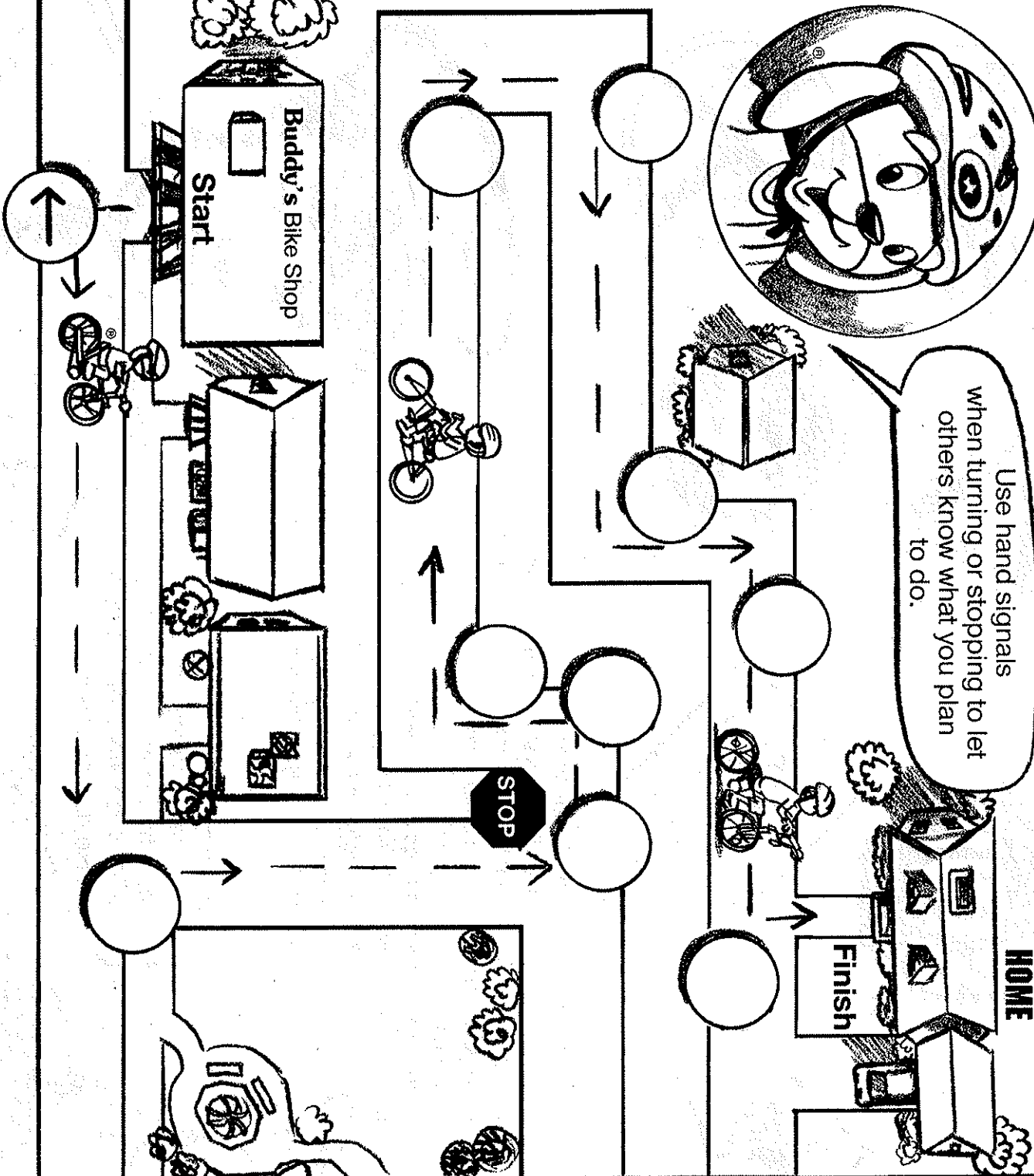

Hand Signal Code:

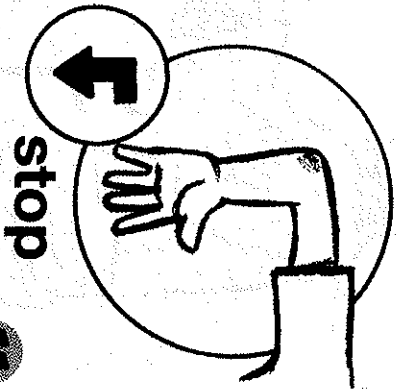
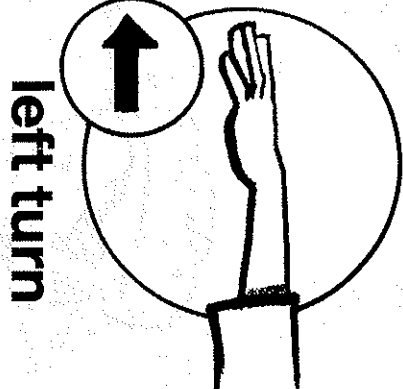
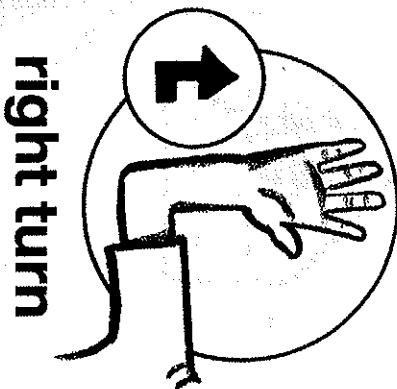

Safety Signs

Directions: Signs have important messages. Put the letter beside each sign in front of the statement below that tells the sign's message.

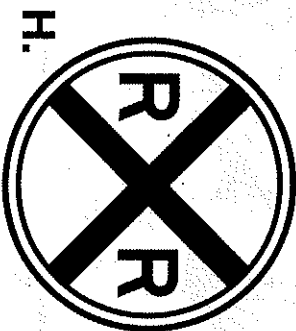
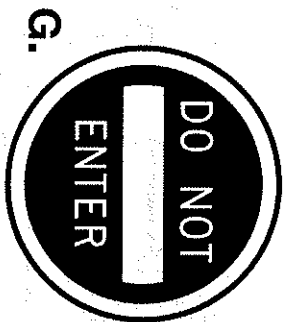
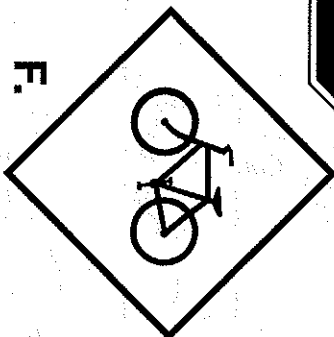
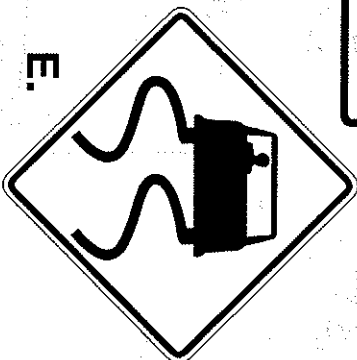
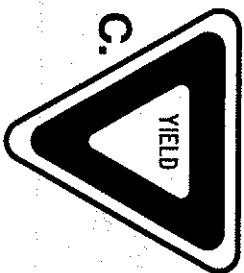

1. School nearby: Watch out for children crossing.
2. Come to a complete stop before starting forward again.
3. Railroad tracks ahead: Look for trains before crossing.
4. Bicycles and cars on the other road have the right of way. Let them go first.
5. You are not allowed to go any further.
6. Bicycles are allowed to cross the street here - watch out for them.
7. Be careful - if the road's wet, this section will be slippery.
8. Traffic can only go the direction the arrow points.

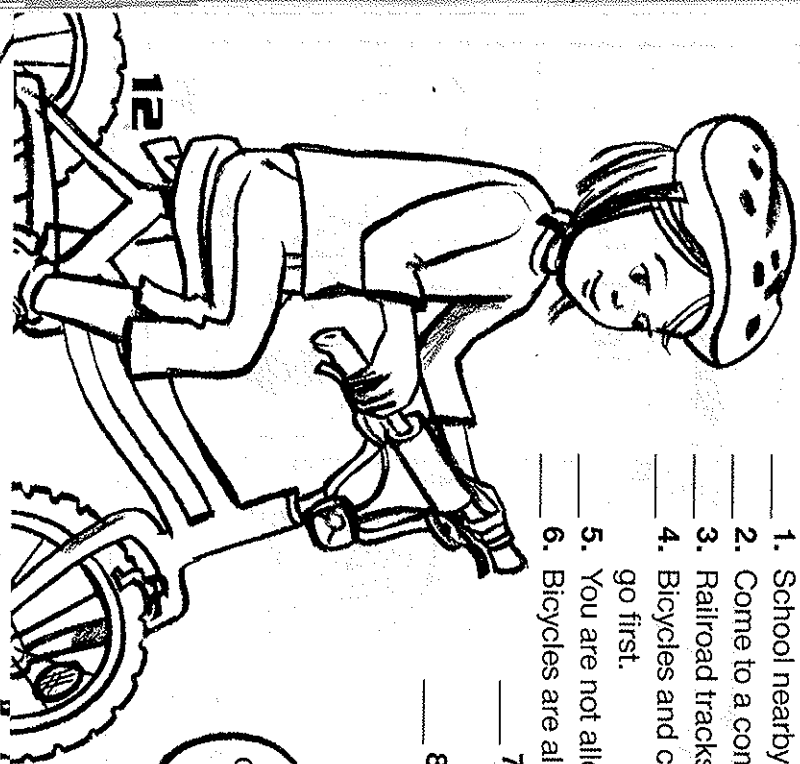

Traffic safety signs are certain shapes and colors, so we can quickly identify them as drivers, bike riders, or pedestrians.



Traffic Safety

Directions: Write "Walk" or "Don't Walk" under each picture. Then read the rules below.

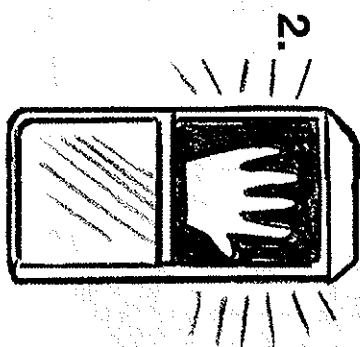
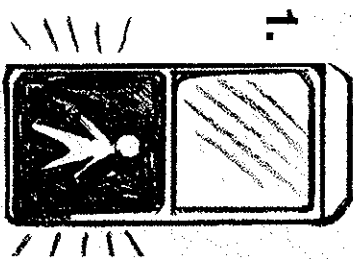

Even when the light says "go" take time to look both ways before you cross the street.

Always cross with the light and walk your bike.

Answers on Page 24

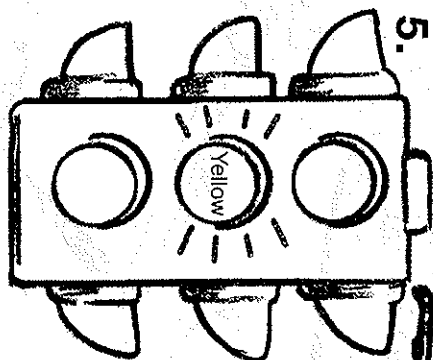
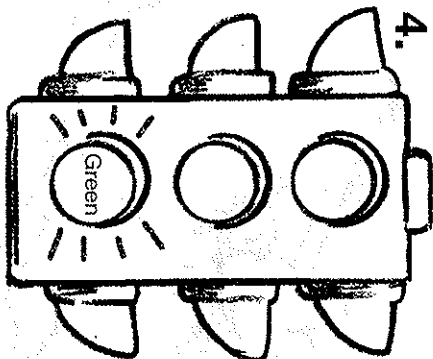
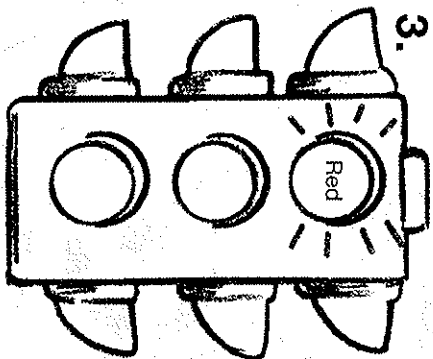

1. Be aware of traffic. Look left, right, and left again before crossing a street.
2. Always walk your bike across the road at a crosswalk or corner.
3. Watch for turning cars and cars backing out of driveways.
4. Follow the rules of the road, just like walkers and car drivers.

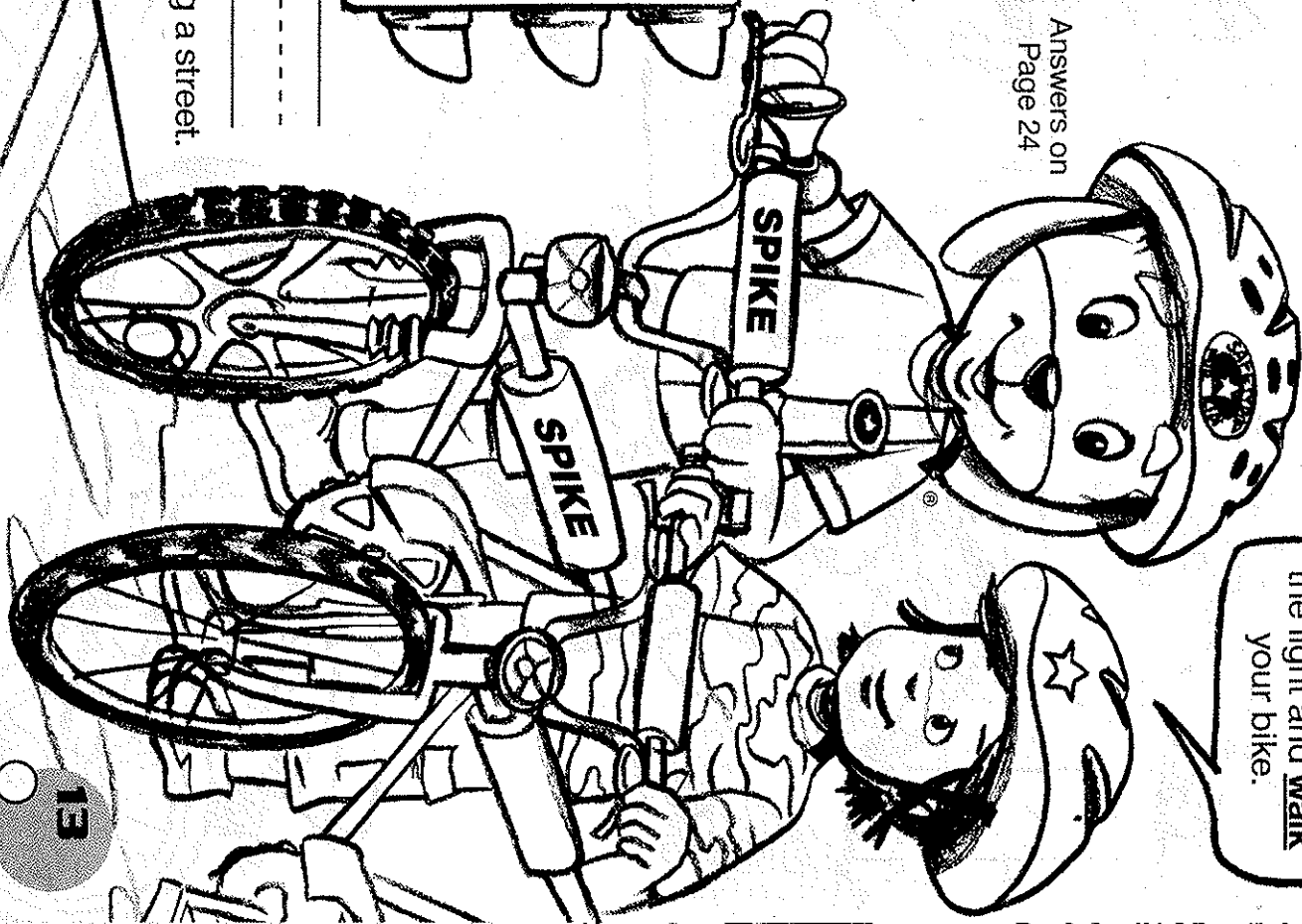

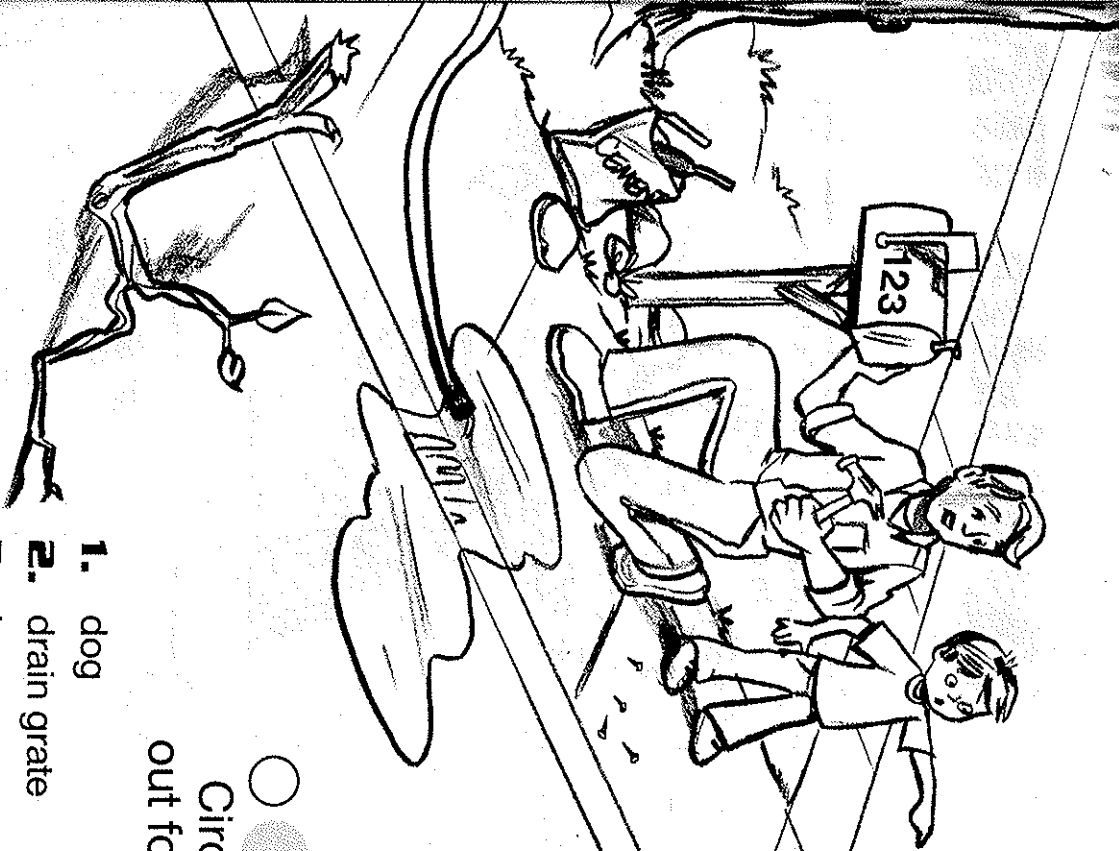

An ambulance or firetruck must drive very fast. Never cross the street when you see or hear one coming.

Directions:
 Circle the hazards to look out for when riding your bike:

- | | |
|----------------------------|----------------------------|
| 1. dog | 10. ball |
| 2. drain grate | 11. broken glass and trash |
| 3. bee | 12. nails |
| 4. broken sidewalk or road | 13. rocks |
| 5. boy | 14. water puddle |
| 6. girl | 15. leaves |
| 7. man | 16. ambulance |
| 8. branch or limb | 17. hose |
| 9. rake | 18. squirrel |



A Ride Of

Directions: Read the bike safety story and number the pictures with the correct rule.

1. Safetypup® knew on this day he would like to call up a buddy and go ride his bike.
2. If he did not check a pedal, tire, or brake, he knew it would be a big mistake.
3. Bike paths are for bikes to ride on, or if on the road, ride on the right-hand side.
4. They remembered rules and traffic signs, too. To ride in single file, it's the right thing to do.
5. "Wear a helmet that fits your head." Is what our friend, Safetypup® said.
6. Hand signals are what you need to learn to let others know when you'll stop or turn.

We're working together to keep you safe on your bike!

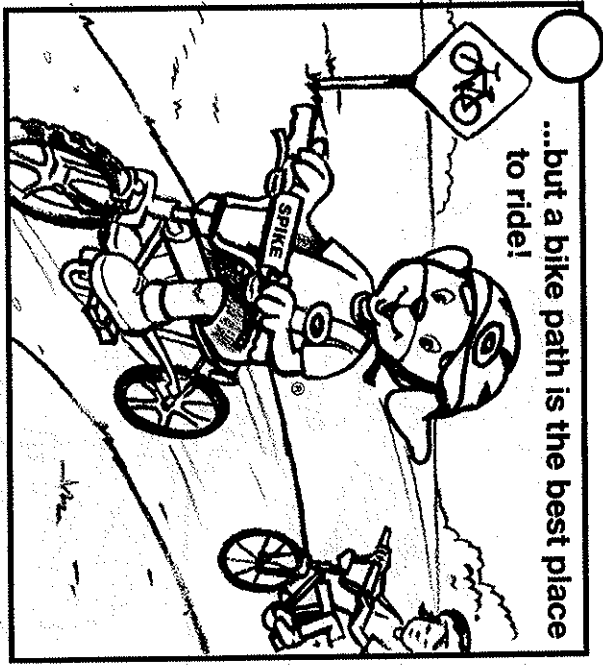

...but a bike path is the best place to ride!

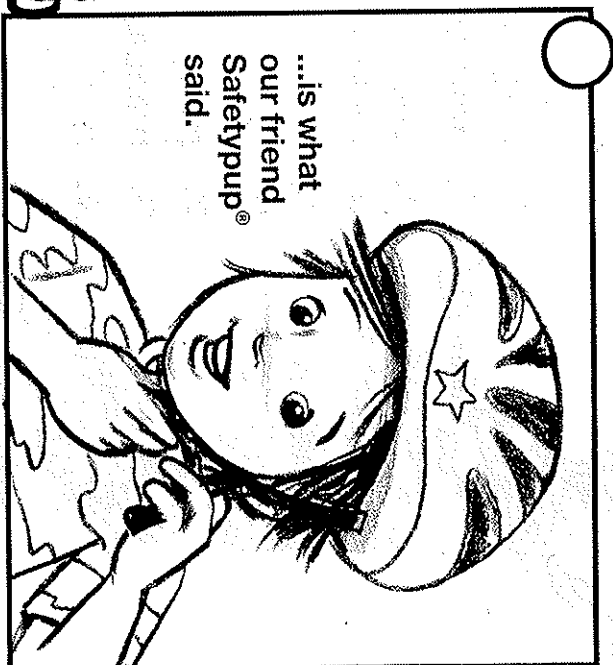

...is what our friend Safetypup® said.



Rhyme In The Park

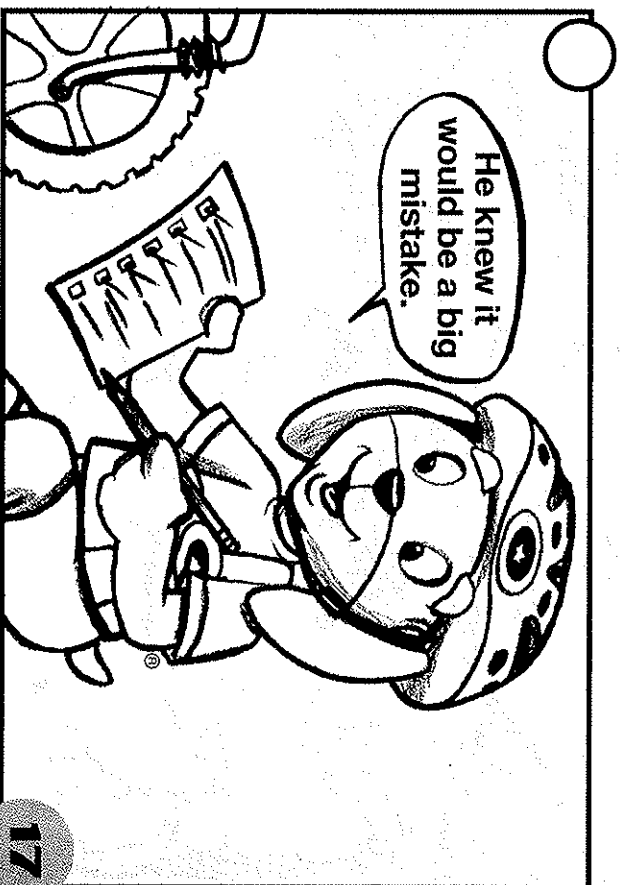
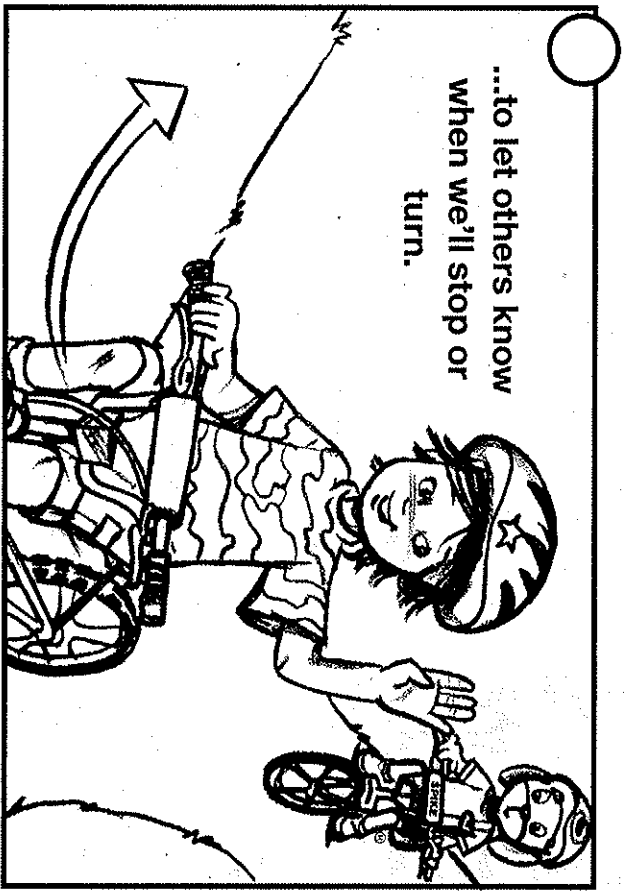
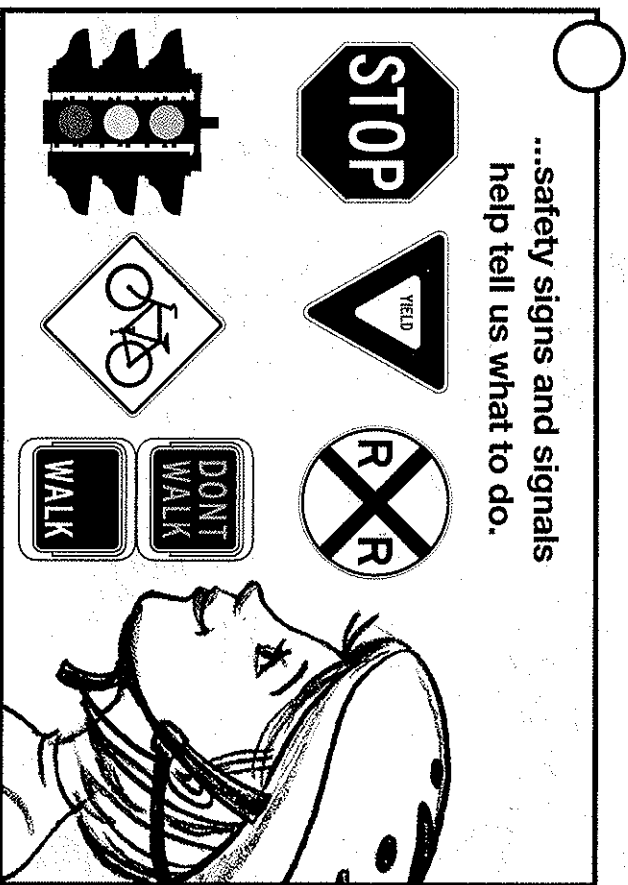
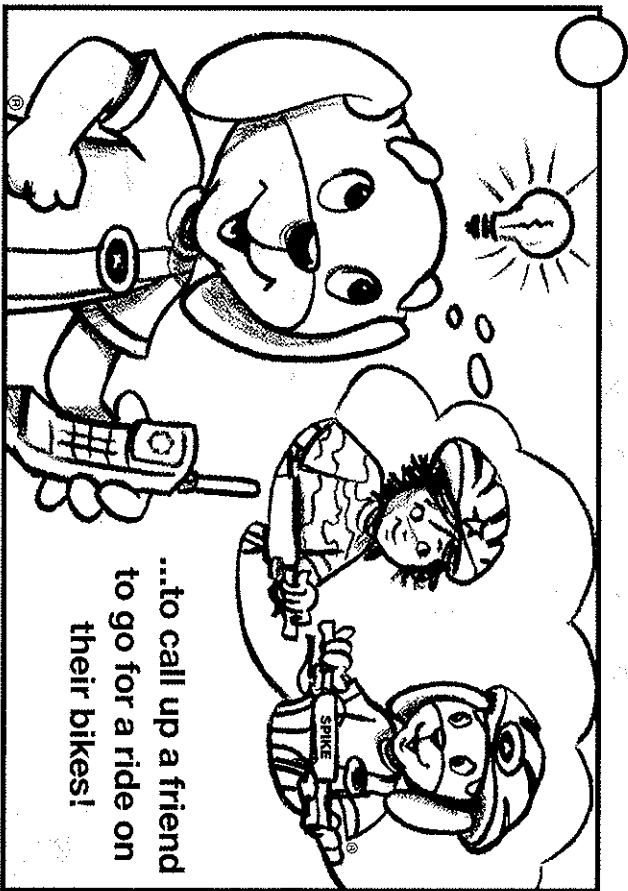

Directions: Finish the title on this page by writing the numbered letters of the wheel below in the matching spaces above. The first one is started for you.

Keep Your

Remember to:

A. L

B.

C.

The "key" to keeping your bike safe is to lock it . . .

SPIKE

SPIKE

... at home or away.

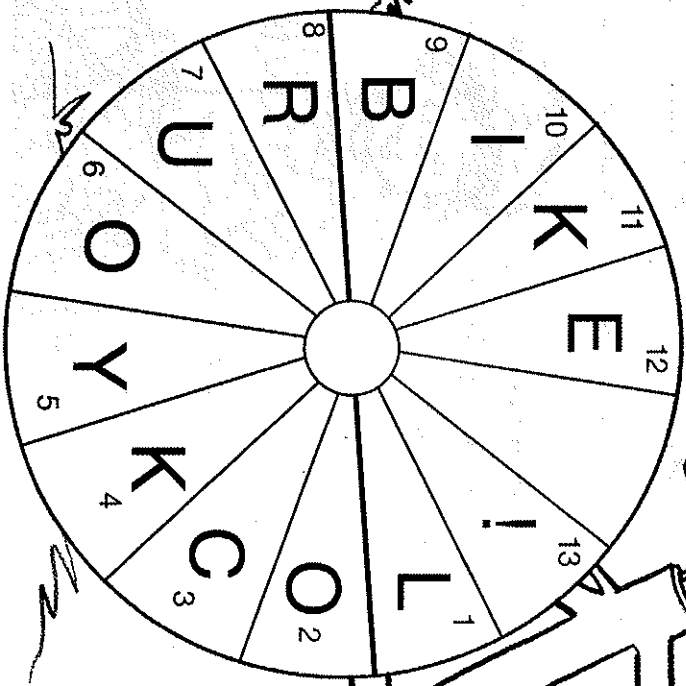

18

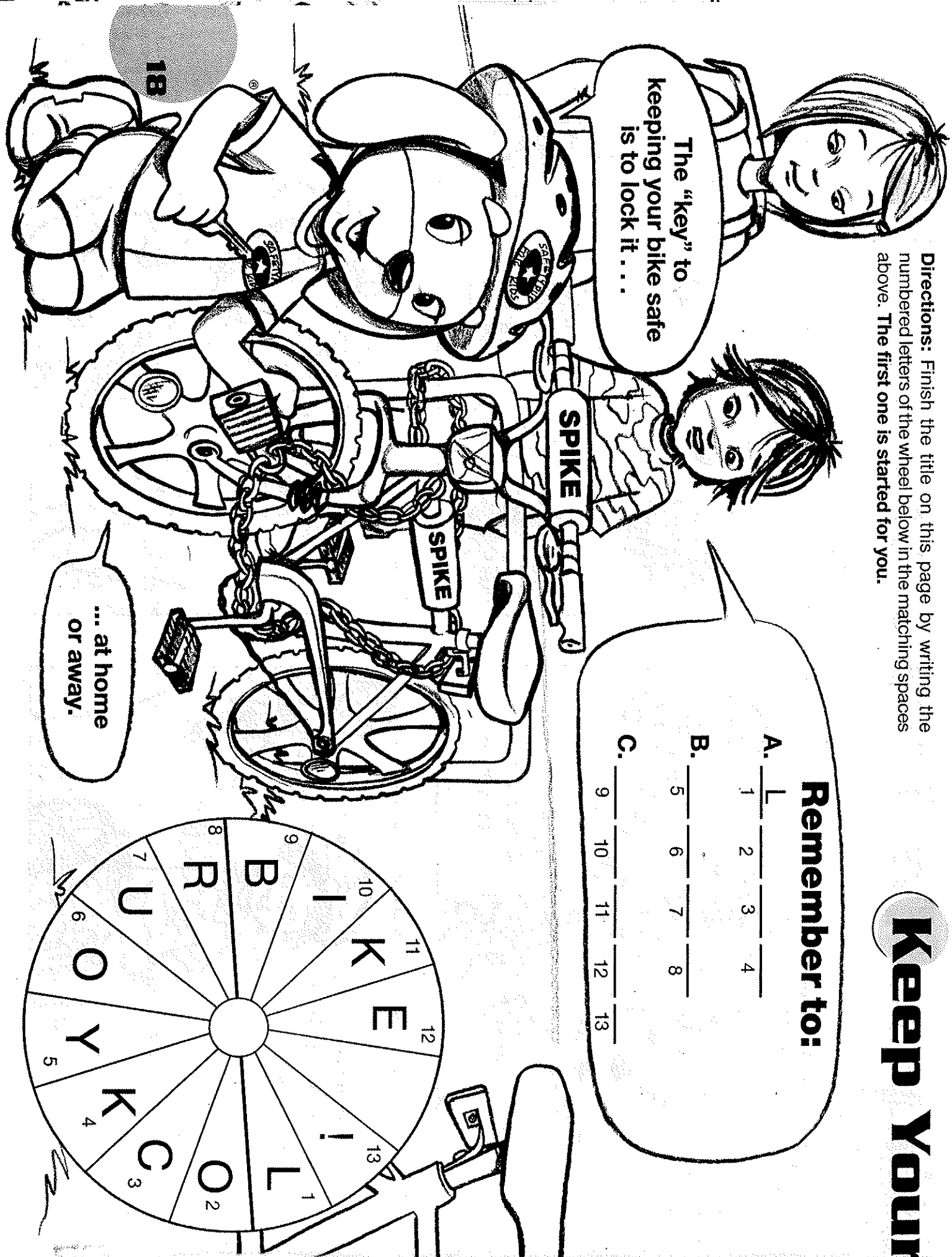

Bike Safe and Sound.

Directions: Use the words from the Word Bank to complete the rules. Then find those words in the wordsearch. Words go: 

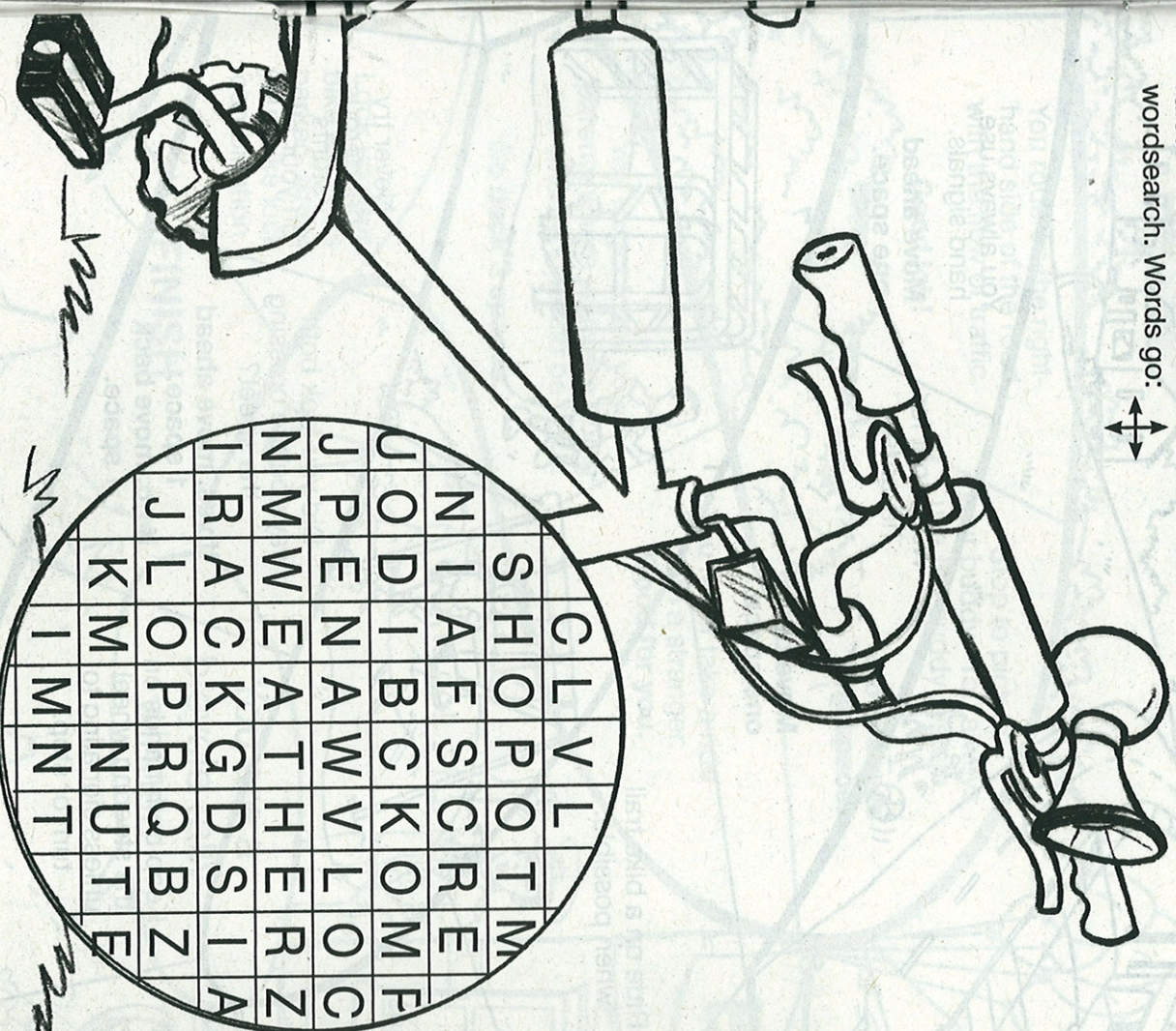

1. Ask a bike _____ which locks work best.
2. Always lock your bike, even if you are only going to leave it for a _____.
3. Lock your bike to a bike _____ when possible.
4. Place a _____ lock through the wheel and bike frame.
5. _____ your lock combination.
6. Keep your bike _____ chain away from wheels, pedals, and the chain when riding.
7. Never leave your bike laying on the _____ or in the driveway.
8. Park your bike, out of the way of people, cars, and inside in bad _____.

Word Bank:

Memorize sidewalk rack lock
 minute shop weather chain

The big bicycle rally day is here!

Rally - Ho! R

START

Ask for permission before leaving your yard.

Walk your bike across the street. Move ahead one space.

Ride on a bike trail when possible.

Move back one space.

Watch out for hazards.

You always use hand signals. Move ahead one space.

Obey all traffic signs & signals when riding your bike.

You took a shortcut through the woods.

Go back to start.

Keep both hands on the steering wheel unless signaling to turn or stop.

Did you look both ways before crossing the street?
If yes, move ahead 1 space.
If no, move back 1 space.

Never try dangerous stunts on your bike.

Buddy Set Go!

Bicycle Safety Game

For 2 - 4 players

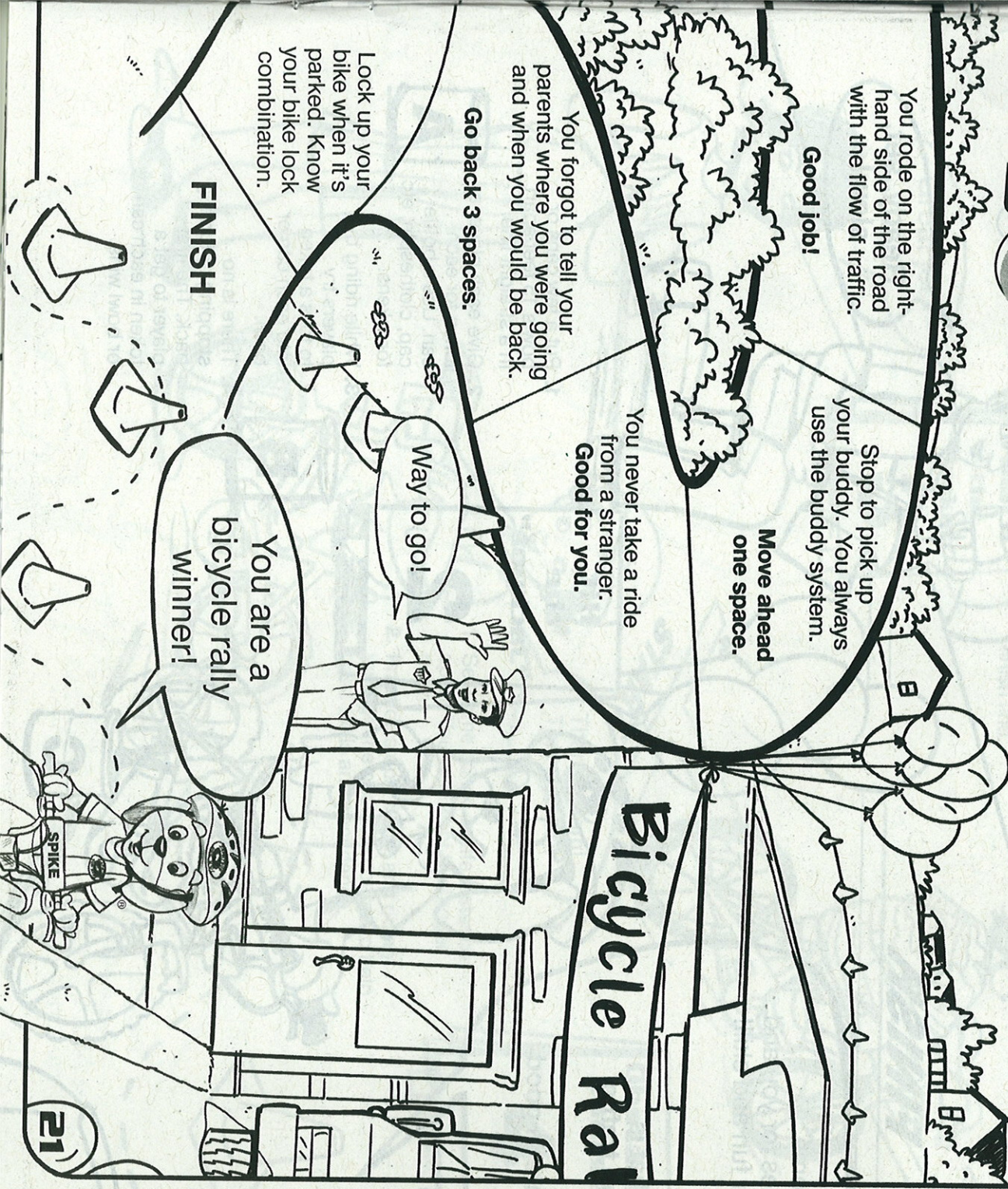

You rode on the right-hand side of the road with the flow of traffic.

Good job!

Stop to pick up your buddy. You always use the buddy system.

Move ahead one space.

You never take a ride from a stranger.

Good for you.

You forgot to tell your parents where you were going and when you would be back.

Go back 3 spaces.

Lock up your bike when it's parked. Know your bike lock combination.

FINISH

You are a bicycle rally winner!

Way to go!

Bicycle Rally

SPIKE

21

Directions:

1. Cut out the playing pieces below.
2. Place the 1 and 2 cards in a hat and draw out of the hat to see how many spaces to move.
3. The other 4 cards are playing pieces.
4. The first person to pick a 2 goes first and the players need to take turns going clockwise (to the player's left).
5. Begin at start. Read each rule you land on and follow any extra instructions.
6. The first player to reach the finish line wins.

1

2



Boy



Girl

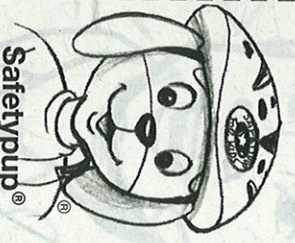

SafetyPup®



Bud

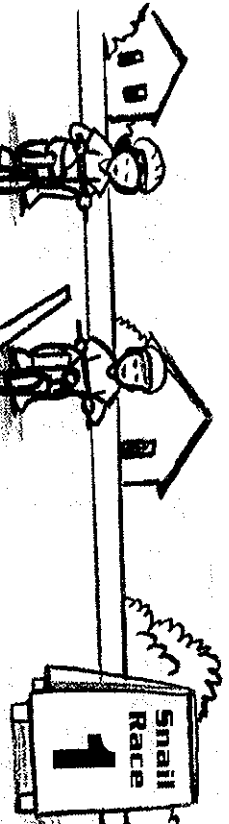

1. Mark off a course 15 feet long. Make 4 foot wide lanes with chalk or string.
2. Stay inside your lane. Feet cannot touch the ground. It's harder to do than it sounds and takes balance and steering skills.
3. The last person to reach the finish line wins.

BIKE

FINISH FINISH

Here are some bike safety rally games for you and your friends to try for fun and skill!

To Plan A Rally:

- Choose a place that is flat and away from traffic.
- Inspect bikes to make sure they are in good condition.

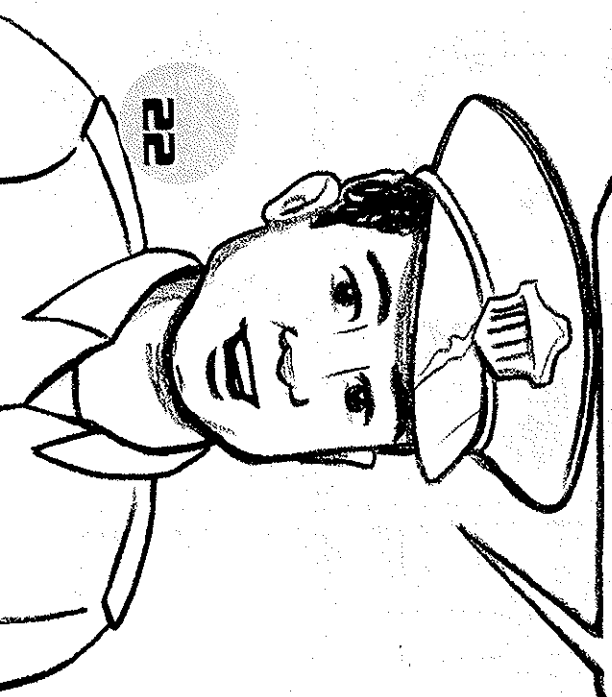

22

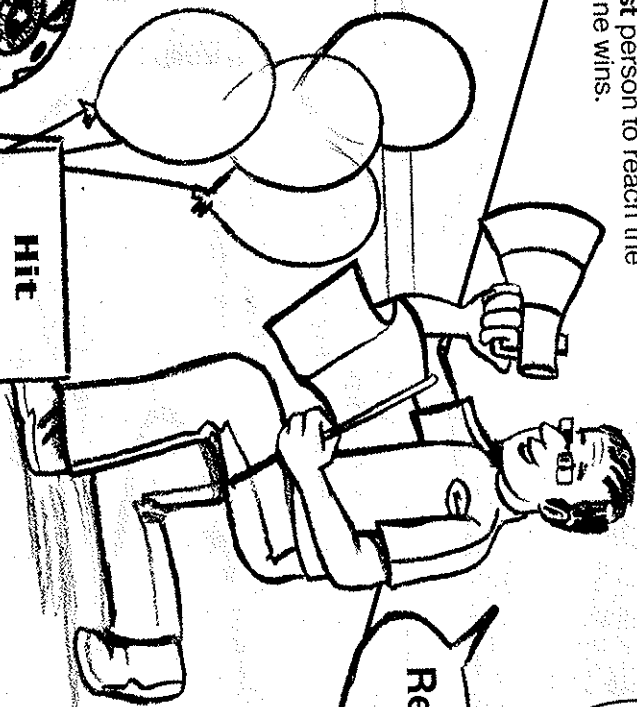

Ready, set, slow!

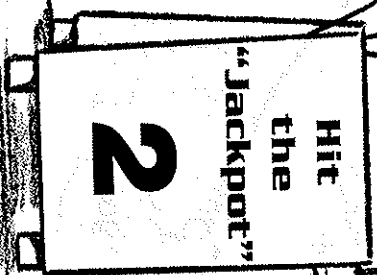

1. Put a few cans or bowls 15 feet apart in a straight line.
2. Give each player a token for each can. Use a bottle cap, clothespin, etc. for tokens.
3. While riding by, players try to toss a token into each can or bowl.
4. There is no stopping or turning back. The first player to get a token in each can or bowl wins.

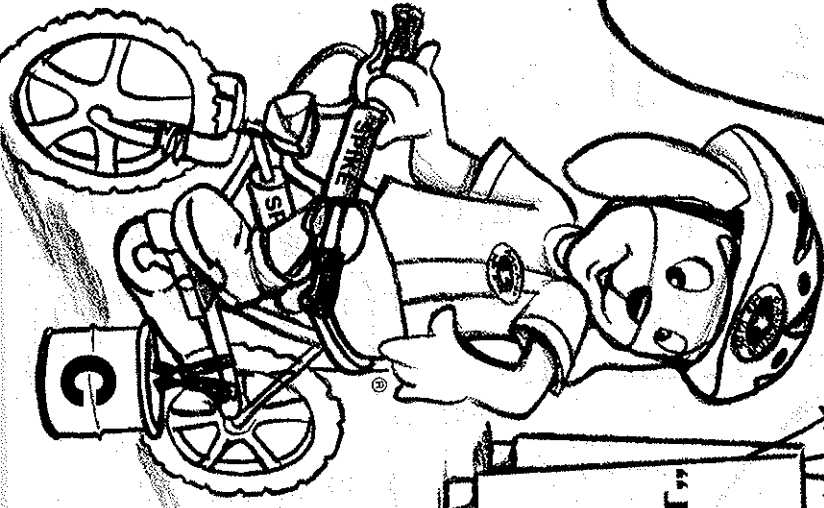

SAFETY RALLY

Great job!

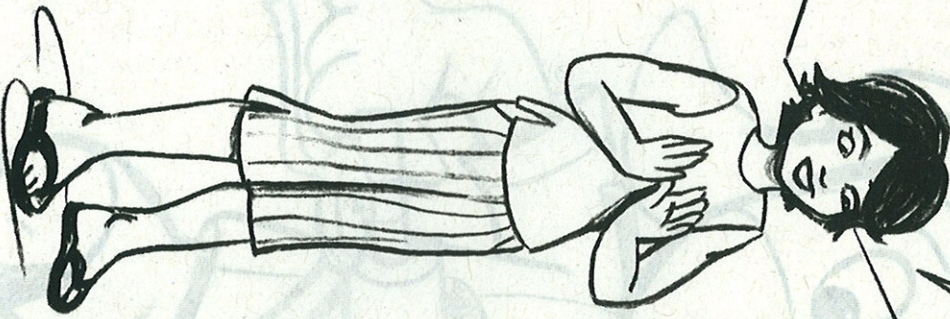

1. Mark off a 100 foot line with chalk or string.
2. Ride 100 feet at medium speed. Come to a smooth, non-skid stop within 10 feet of the finish line.



Thanks mom! That was fun!

1. Set some cones a safe distance apart. You may want to stagger them.
2. Practice stops, turns, and riding through the obstacle course to help build skills and confidence.

Everyone is a winner with bike safety!



1

FINISH

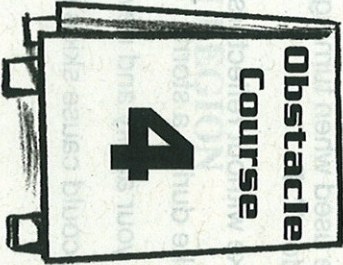
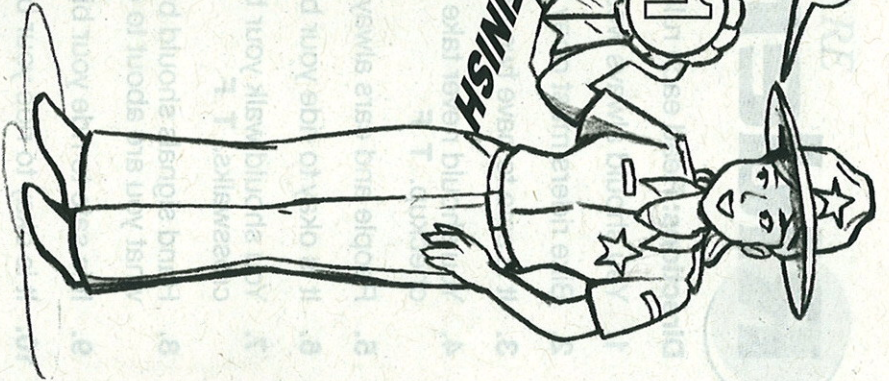

If you are a beginner or have not been on a bike in a while take it slow. This game is not a race.

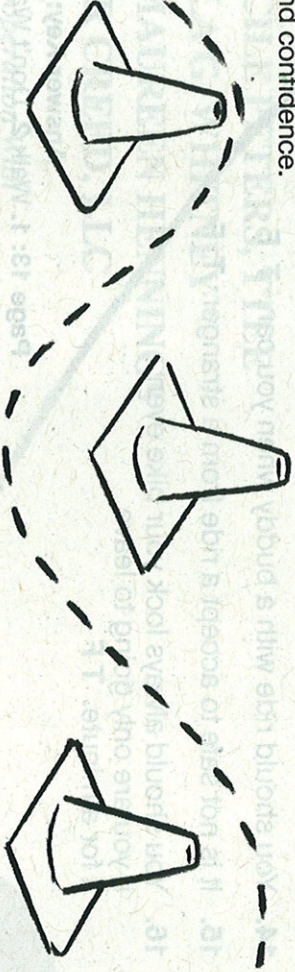

Rider Review

Directions: Read each rule and circle T for True or F for False.

1. You should always wear a safety-approved helmet that fits you. T F
2. Bike riders must obey traffic lights just like car drivers. T F
3. It is safe to have two people on a bike. T F
4. You should never take your bike to a bike mechanic or bike shop for a checkup. T F
5. People and cars always go first. T F
6. It is okay to ride your bike with no hands. T F
7. You should walk your bike through busy intersections and stay within the crosswalks. T F
8. Hand signals should be used when turning or stopping to let others know what you are about to do. T F
9. It is safe to ride your bike without reflectors. T F
10. It is okay to ride your bike during a storm. T F
11. You should only ride to your ability and never do stunts. T F
12. Hazards are things that could cause skids or falls when riding a bike. T F
13. It is not necessary to ask your parents for permission before leaving your yard or to tell them where you are going. T F
14. You should ride with a buddy when you can. T F
15. It is not safe to accept a ride from a stranger. T F
16. You should always lock your bike even if you are only going to leave it for a minute. T F

Thanks for riding with me and with "Spike." We hope you stay SAFE and SOUND on your bike!



Answer Key:

Page 13: 1. Walk 2. Don't Walk 3. Don't

Walk 4. Walk 5. Don't Walk

Page 24: 1. T, 2. T, 3. F, 4. F, 5. T, 6. F, 7. T, 8. T, 9. F, 10. F, 11. T, 12. T, 13. F, 14. T, 15. T, 16. T

PROVIDED AS A PUBLIC SERVICE BY PEOPLE WHO CARE

Deschutes County, Oregon

La Pine

EXACT CONSTRUCTION

GARY AND SANDY'S APPLIANCE, TV'S AND MORE

HOLY REDEEMER CHURCH

LA PINE BUILDING SUPPLY / ACE HARDWARE

LINDA MAGGARD

MIDSTATE ELECTRIC

RANDY YOW CONSTRUCTION, INC.

Redmond

DANA SIGNS

RAY JOHNSON POST #44 AMERICAN LEGION

Sisters

BLACK BUTTE RANCH

C. W. & MARY ZILK

CHARLES & BETTY FADELEY

DIERK & CECILE PETERS, TTEE

J. & WILLA G. WHITNEY

RAYMOND & MAUREEN HENNINGS

WAGNER CREED, LLC

In Cooperation With

THE DESCHUTES COUNTY SHERIFF'S OFFICE

LARRY BLANTON, SHERIFF

PROVIDED AS A PUBLIC SERVICE BY PEOPLE WHO CARE

Deschutes County, Oregon

Bend

APPROVED CREDIT, INC.
 BEND DERMATOLOGY CLINIC, LLC
 BEND DRYWALL, LLC
 BEND ELKS LODGE NO. 1371
 BEND GARBAGE & RECYCLING
 BEND PLUMBING & HEATING
 BRUCE L. FOX, GENERAL CONTRACTOR
 CALVARY CHAPEL BEND
 CARL & EUGENIA JUHL
 CARLSON SIGN
 CENTRAL OREGON ROOFING
 CLYDE W. PURCELL
 COLM COMMERCIAL REAL ESTATE SERVICES
 CSARE PROPERTIES, LLC
 DEJA VU INTERIORS, LLC
 DENTISTRY FOR KIDZ
 DR. CARL RYAN & ASSOCIATES
 DR. GARY GALLAGHER OF NORTHWEST COSMETIC SURGERY
 EL BURRITO RESTAURANT
 HARRIGAN, PRICE, FRONK & CO., LLP
 HOOKER CREEK COMPANIES, LLC
 JEANNE WADSWORTH-WILLIAM HOWELL
 JOHN & MIRIAM CARPENTER
 LASER MEDICAL, P.C./AESTHETICS, M.D.
 LINDSAY STEVENS
 LONGREACH CONCRETE PUMPING, LLC
 LOREN & SALLY IRVING
 LOUIS C. WAMPLER TAX SERVICE

M. JAMIE McALLISTER, D.O., P.C.
 MARTHA & MICHAEL BREEN
 MARVIN MIX & MOLLY NOPP
 MASTERCRAFT CLEANERS
 MATT FALKENSTEIN, D.D.S., P.C.
 MERLOT MORTGAGE, INC.
 MID OREGON CREDIT UNION
 MR. & MRS. ERNEST BLANTON
 NEIL & MARY ELLYN DAVIS
 NEUROLOGY OF BEND
 NEWPORT ONE MARKET
 NOSLER, INC.
 PATRICIA & JERRY ROOD
 PLATEAU WOOD WORKS
 PROFESSIONAL AUTO BODY
 RESORT RESOURCES, INC.
 RICHARD & EVELYN HEUER
 SCHLOTZSKY'S DELI
 SECOND NATURE - CASCADES, INC.
 SERVICEMASTER CLEANING SPECIALISTS
 SUSAN I. MOON, CPA
 THE ARK ANIMAL CLINIC
 THEODORE CHAR LYSTER, III
 BRICKKICKER HOME INSPECTION
 THOMPSON PUMP
 TRESOEURS DESIGN, INC.
 TUMALO FARMS, LLC
 VETERANS OF FOREIGN WARS POST 1643
 WARREN JOHN WEST, P.C., ATTORNEY AT LAW

In Cooperation With

THE DESCHUTES COUNTY SHERIFF'S OFFICE
 LARRY BLANTON, SHERIFF